

MATHEMATICS

RESOURCE PACK
GRADE 11 TERM 3



MEASUREMENT

RESOURCE 1

TOPIC 1 LESSON 1

Example 1

A pyramid with a square base with a side length of 16cm is sketched below. P lies on the square base directly below A. The volume of the pyramid is 640cm^3 .

Volume of a pyramid = $\frac{1}{3}Ah$.

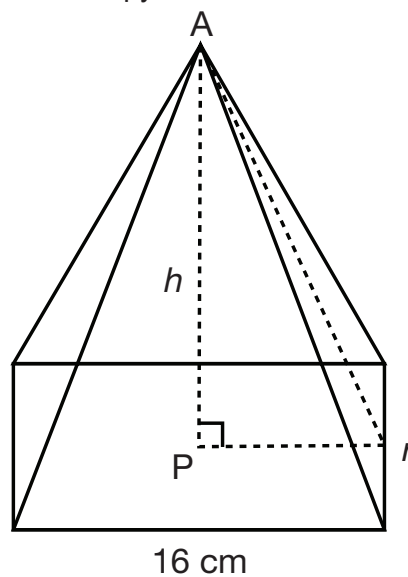

- Show that the perpendicular height of the pyramid, AP, is 7,5cm.
- Hence, determine the total surface area of the pyramid.

NSC NOV 2017

Example 2

A solid metallic hemisphere has a radius of 3cm. It is made of metal A. To reduce its weight, a conical hole is drilled into the hemisphere (as shown in the diagram) and it is completely filled with a lighter metal B. The conical hole has a radius of 1,5cm and a depth of $\frac{8}{9}$ cm

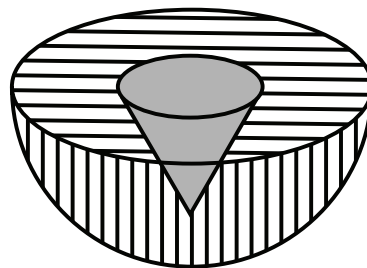

Calculate the ratio of the volume of metal A to the volume of metal B.

EXEMPLAR 2013

RESOURCE 2

TOPIC 1 LESSON 2

Example 3

A cylindrical aerosol can has a lid in the shape of a hemisphere that fits exactly on the top of the can. The height of the can is 16cm and the radius of the base of the can is 2,9cm.

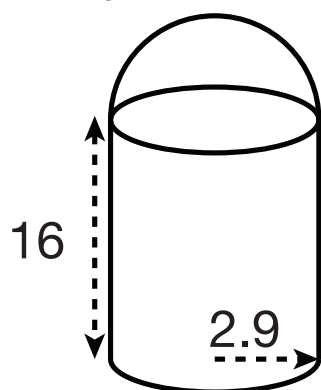

Figure 1

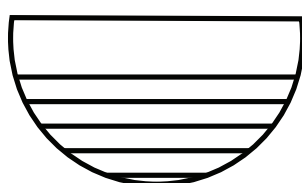

Figure 2

$$\text{Volume of a sphere} = \frac{4}{3}\pi r^3$$

$$\text{Surface area of a sphere} = 4\pi r^2$$

- Calculate the surface area of the can with the lid in place, as shown in FIGURE 1.
- If the lid is 80% filled with a liquid, as shown in FIGURE 2, calculate the volume of the liquid in the lid.

NSC NOV 2016

Example 4

The diagram below shows a water tank which is made up of a cylinder and a cone having equal radii. The height of the tank is 1,8m and the radius is 0,5m. The angle between the perpendicular height, AB, and the slant height, AC, of the conical section is 35,5°.

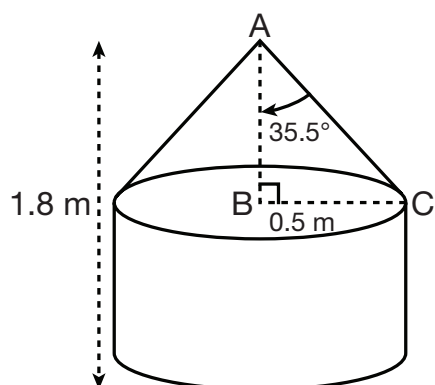

$$\text{Volume of a cone} = \frac{1}{3}\pi r^2 h$$

$$\text{Total surface area of cone} = \pi r^2 + \pi r s$$

$$\text{Volume of cylinder} = \pi r^2 h$$

$$\text{Total surface area of cylinder} = 2\pi r^2 + 2\pi r h$$

- Calculate the perpendicular height, AB, of the cone.
- When the tank is full, an electric pump switches on, and pumps the water from the tank into an irrigation system at a rate of 0,52m³/h. The pump automatically switches off when the tank is full. Calculate how long, in hours, the pump feeds water into the irrigation system.

NSC NOV 2015

EUCLIDEAN GEOMETRY

RESOURCE 3

TOPIC 2 LESSON 2

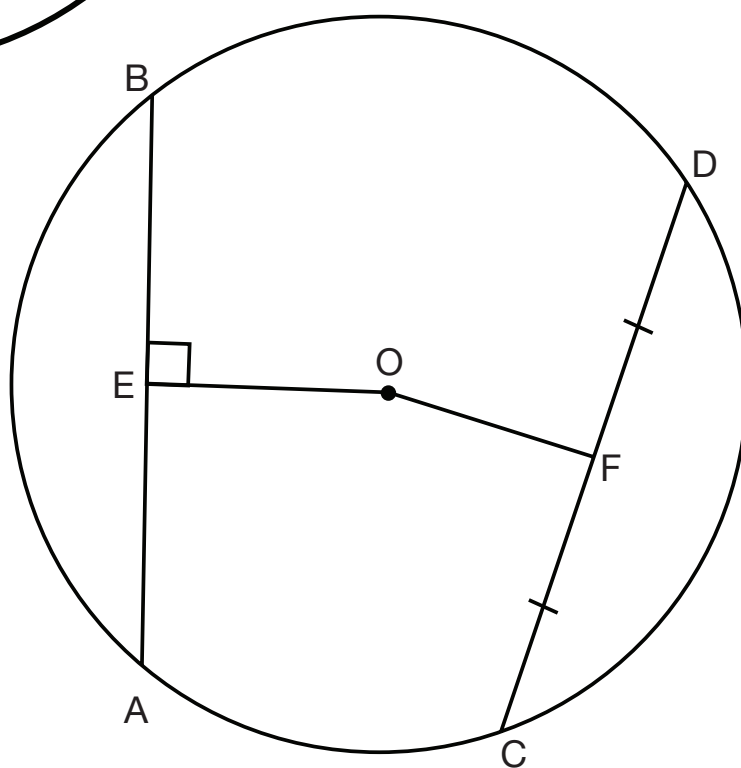
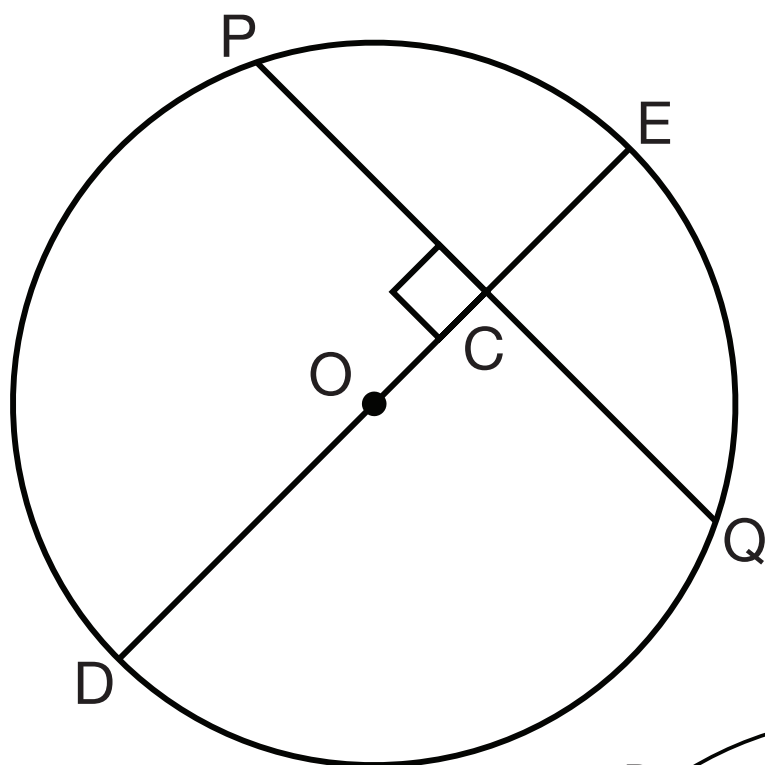

RESOURCE 4

TOPIC 2 LESSON 3

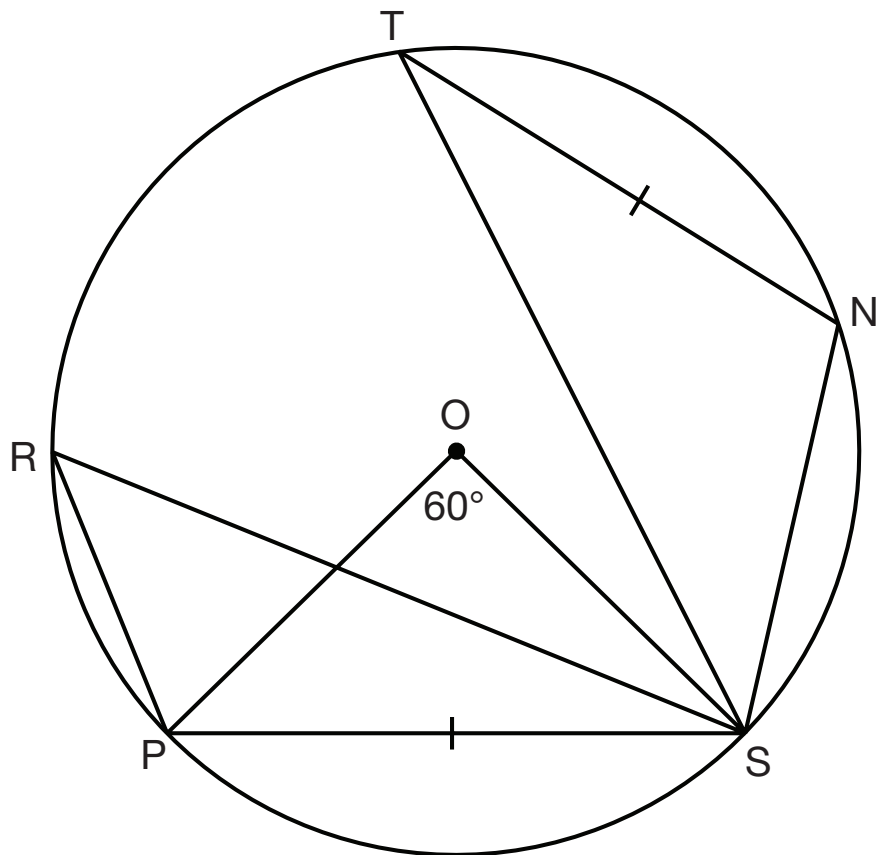
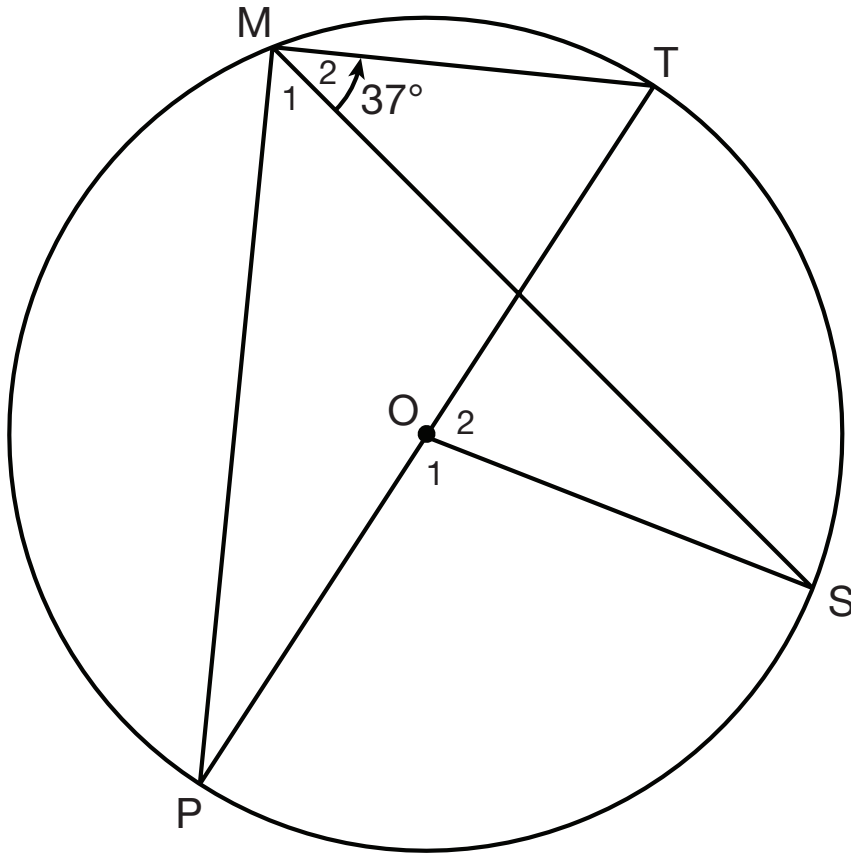

RESOURCE 5

TOPIC 2 LESSON 4

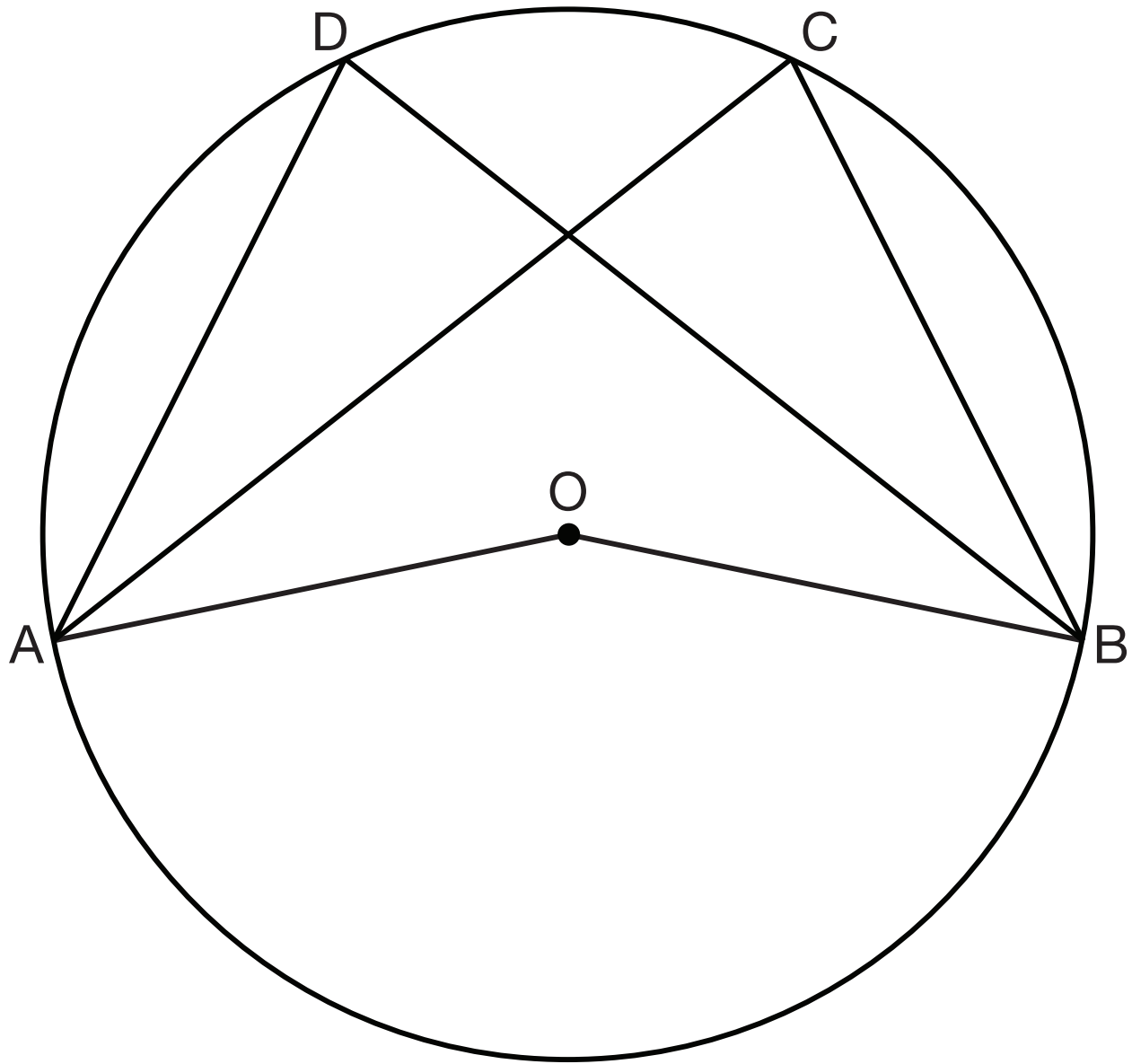

RESOURCE 6

TOPIC 2 LESSON 4

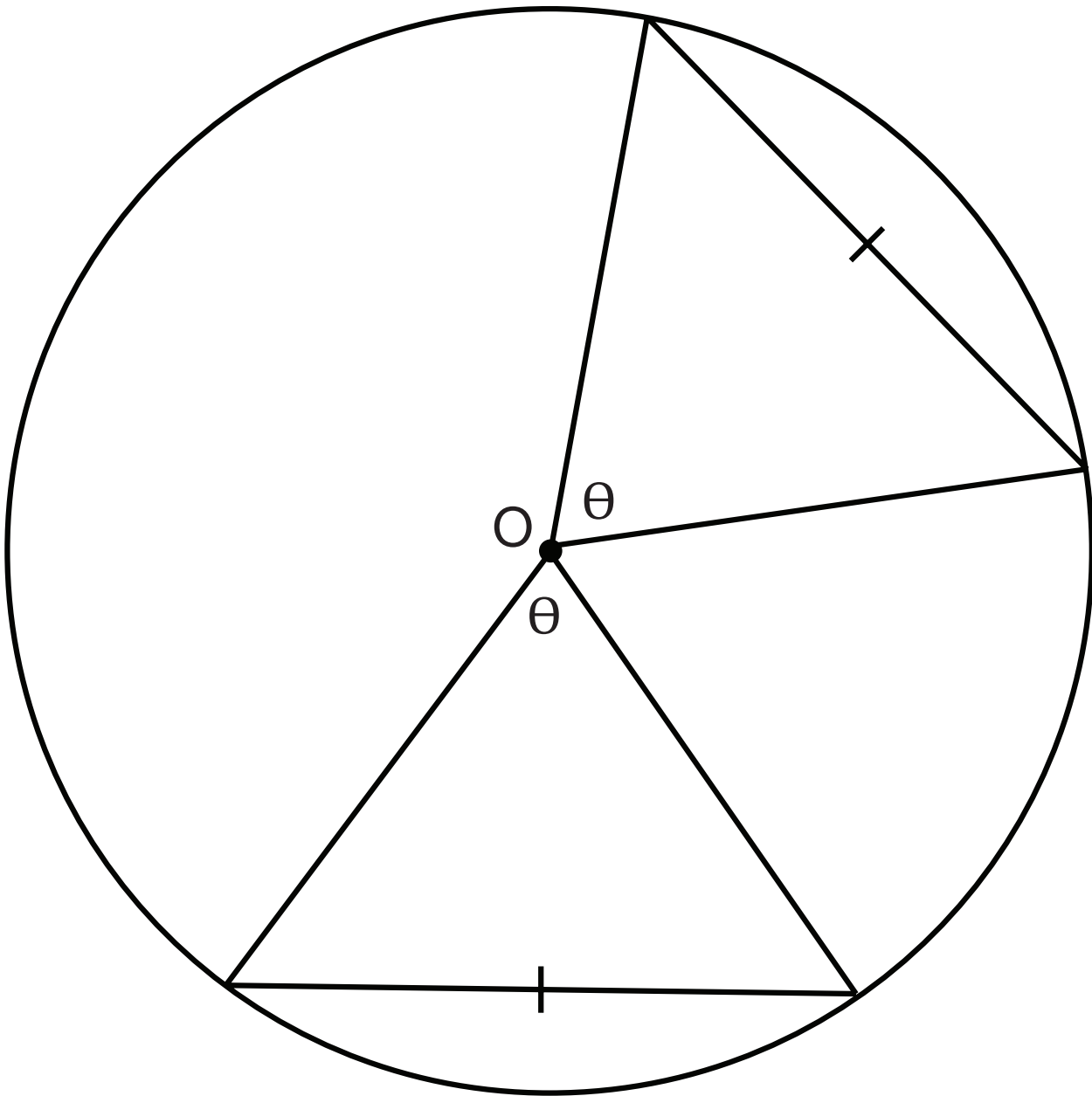

RESOURCE 7

TOPIC 2 LESSON 4

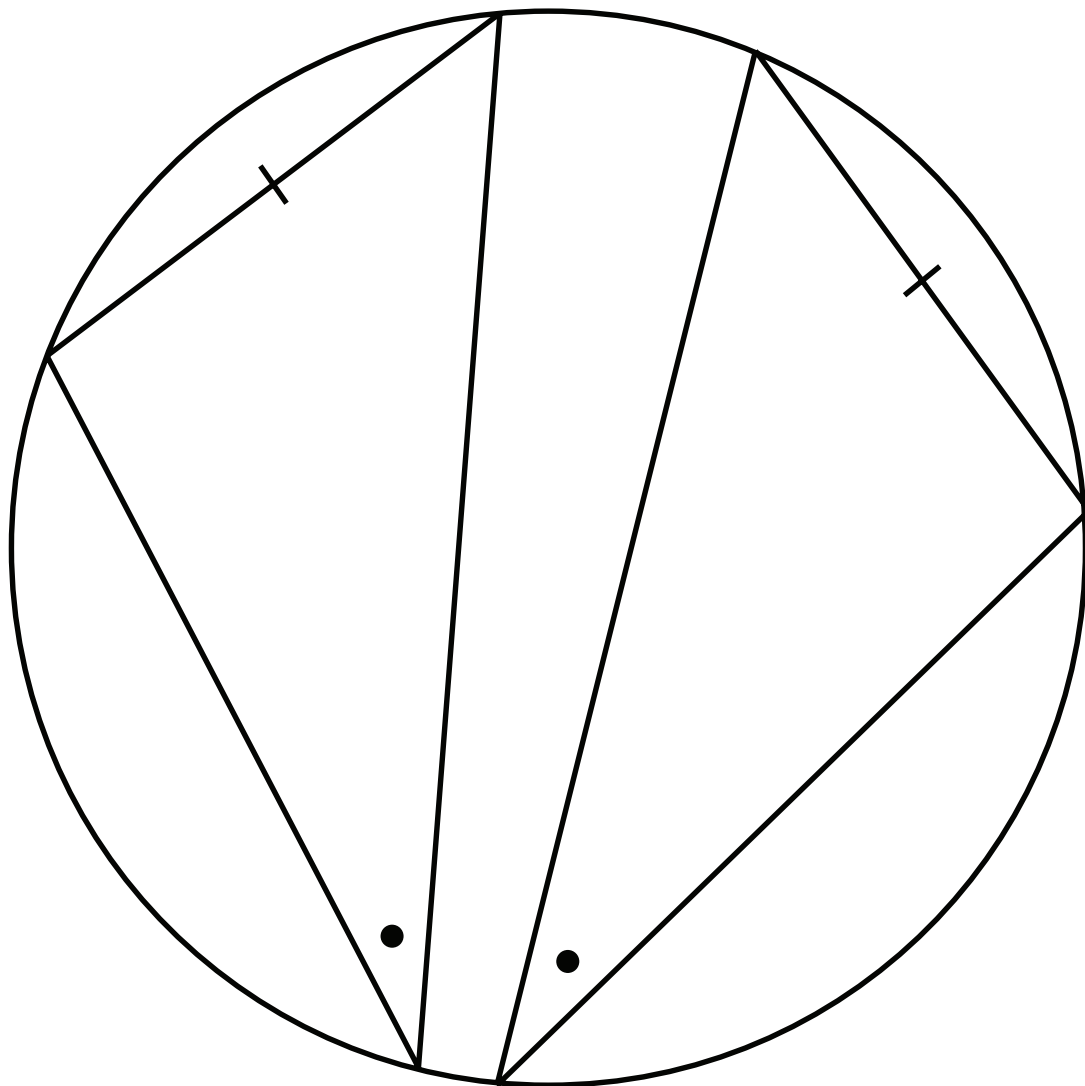
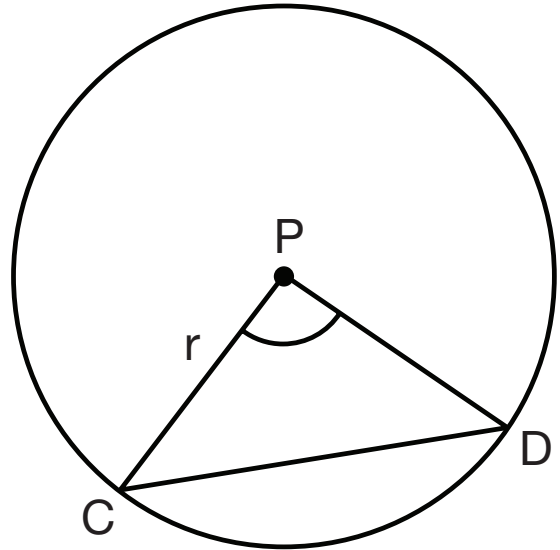
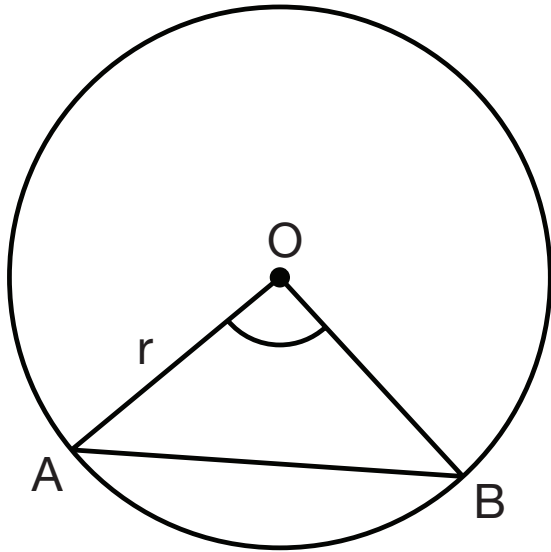

RESOURCE 8

TOPIC 2 LESSON 4

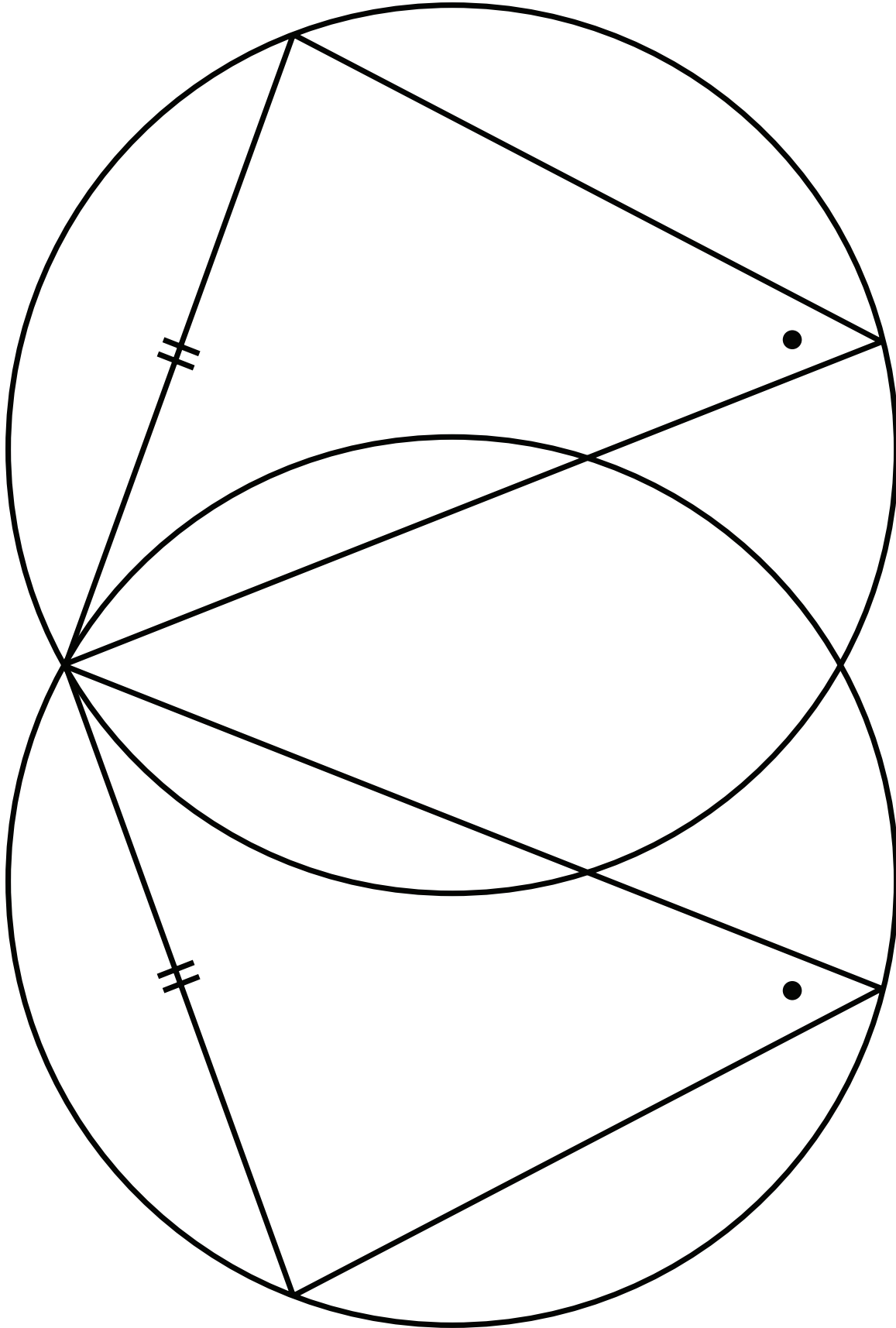

RESOURCE 9

TOPIC 2 LESSON 4

Example 1

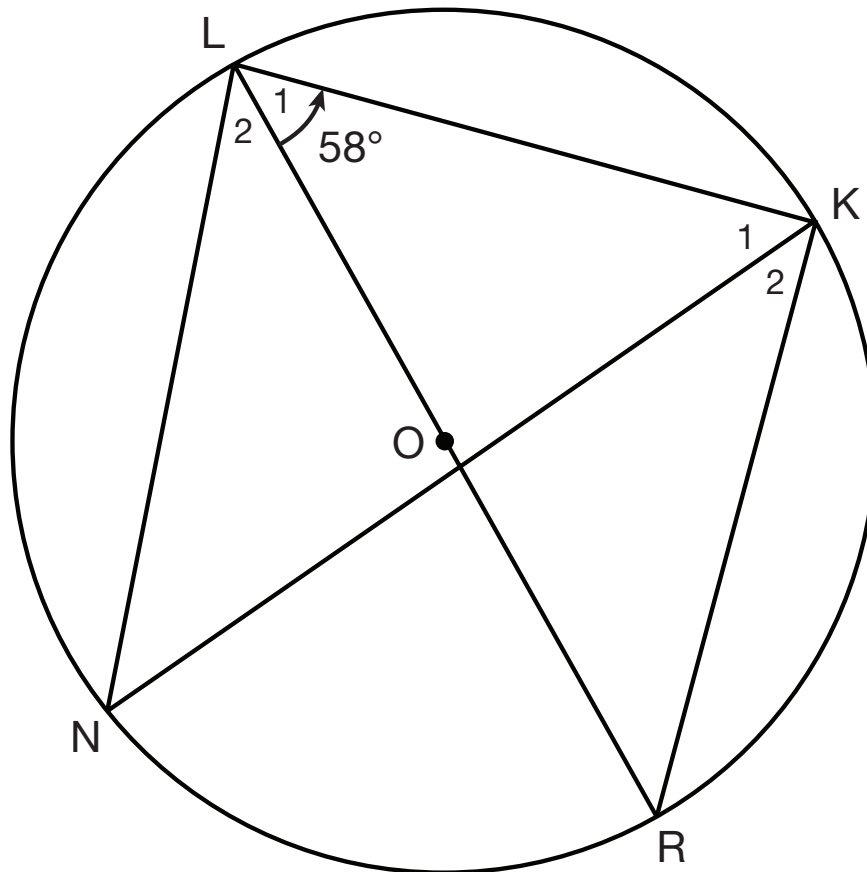

Example 2

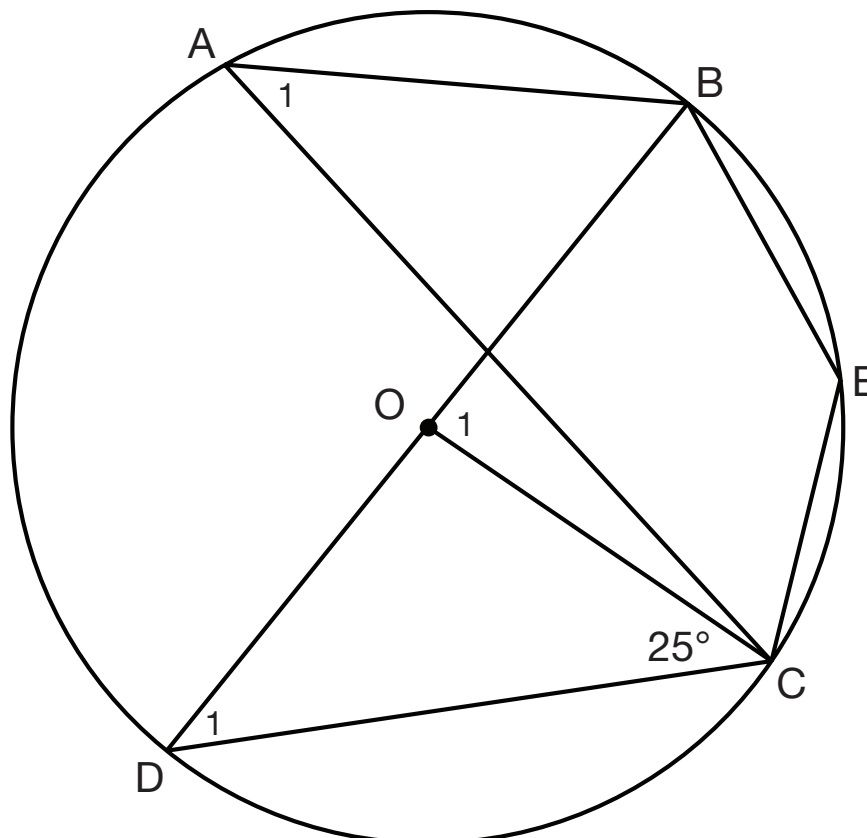

RESOURCE 10

TOPIC 2 LESSON 5

Example 1

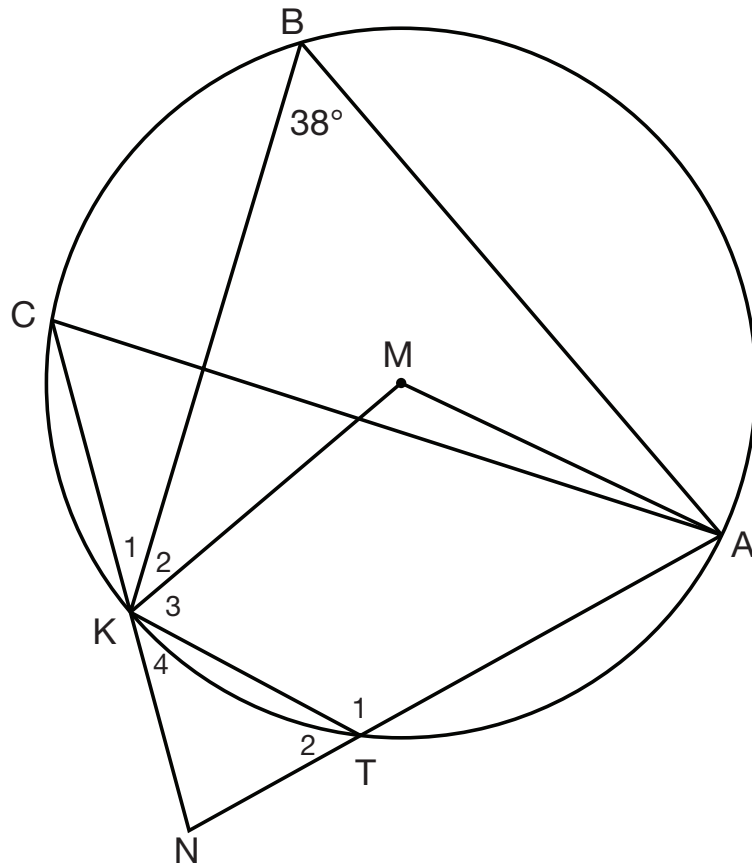

Example 2

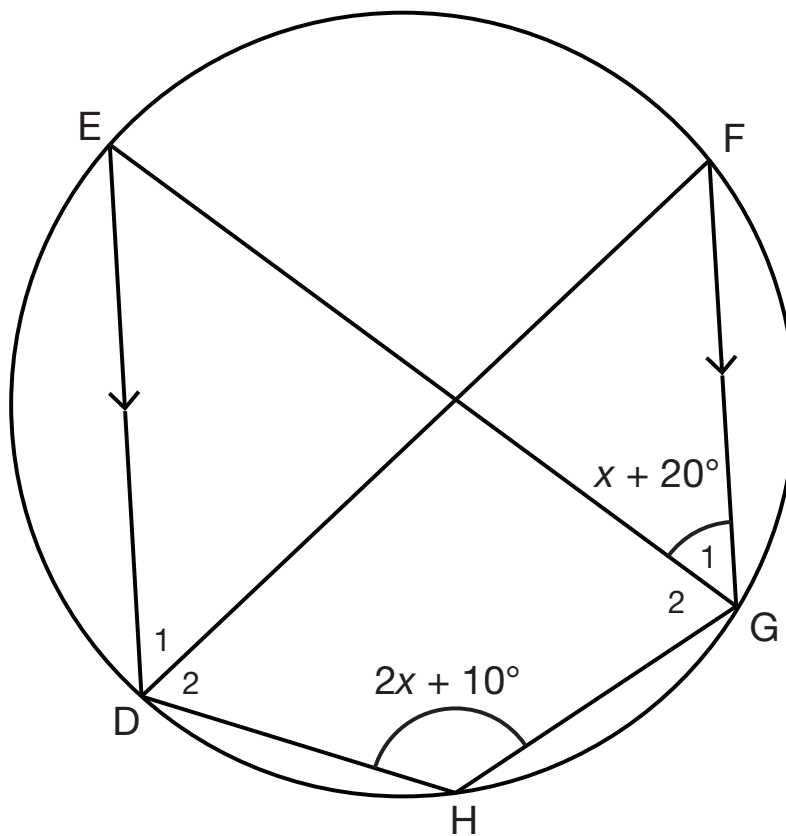

RESOURCE 11

TOPIC 2 LESSON 6

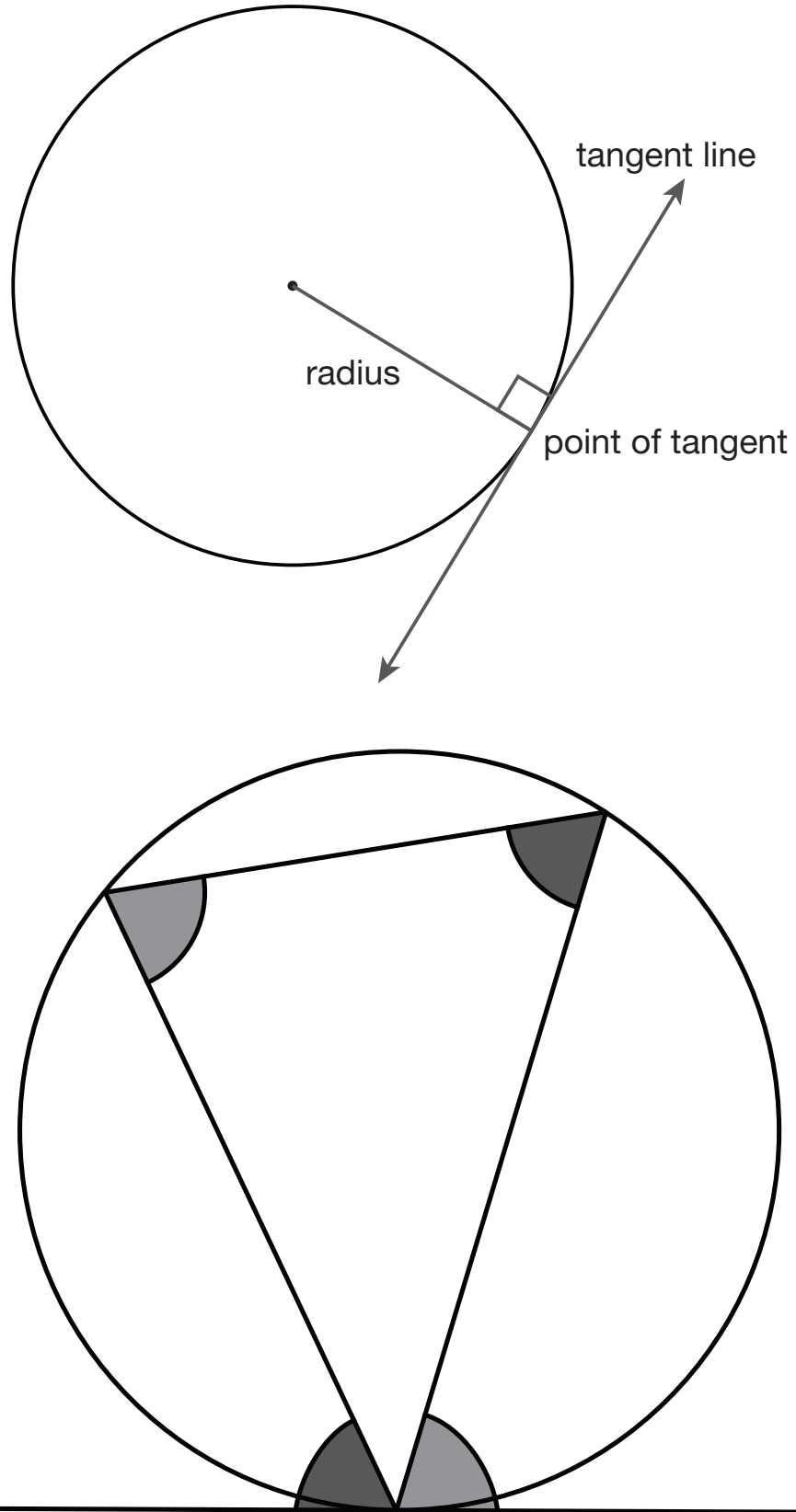

RESOURCE 11

TOPIC 2 LESSON 6

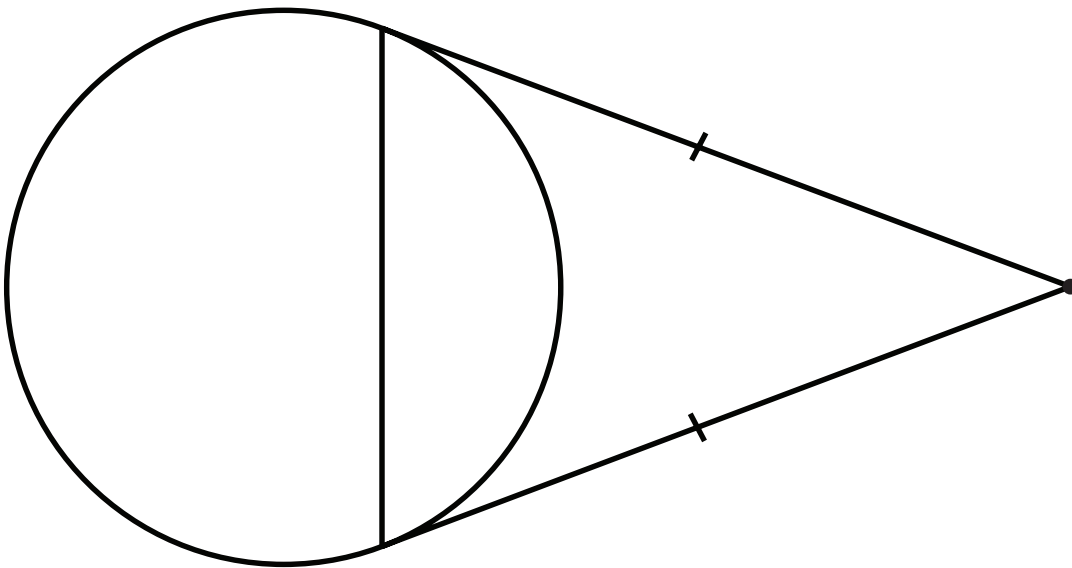
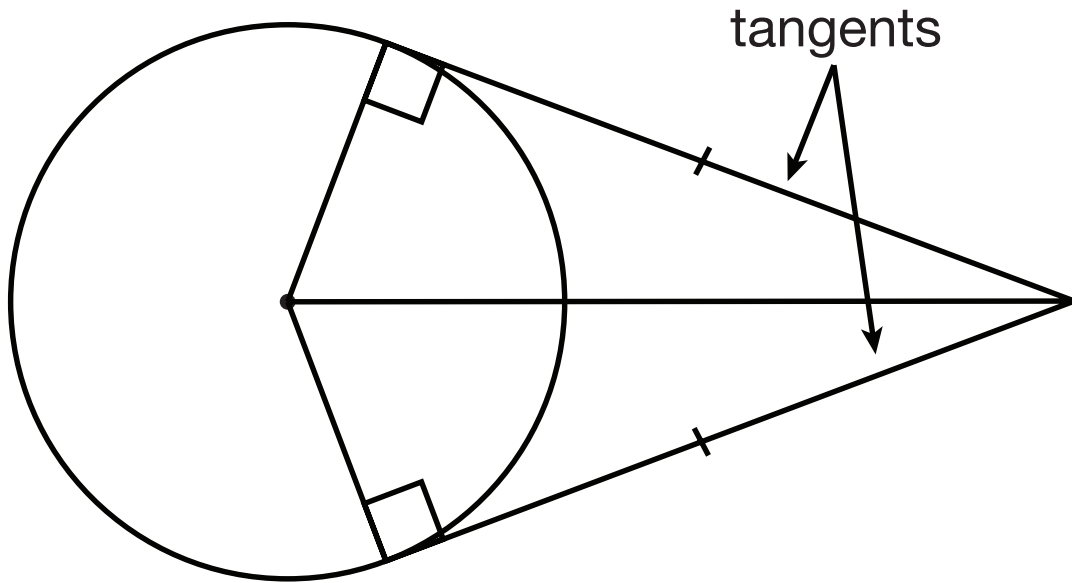

RESOURCE 12

TOPIC 2 LESSON 6

Example 1

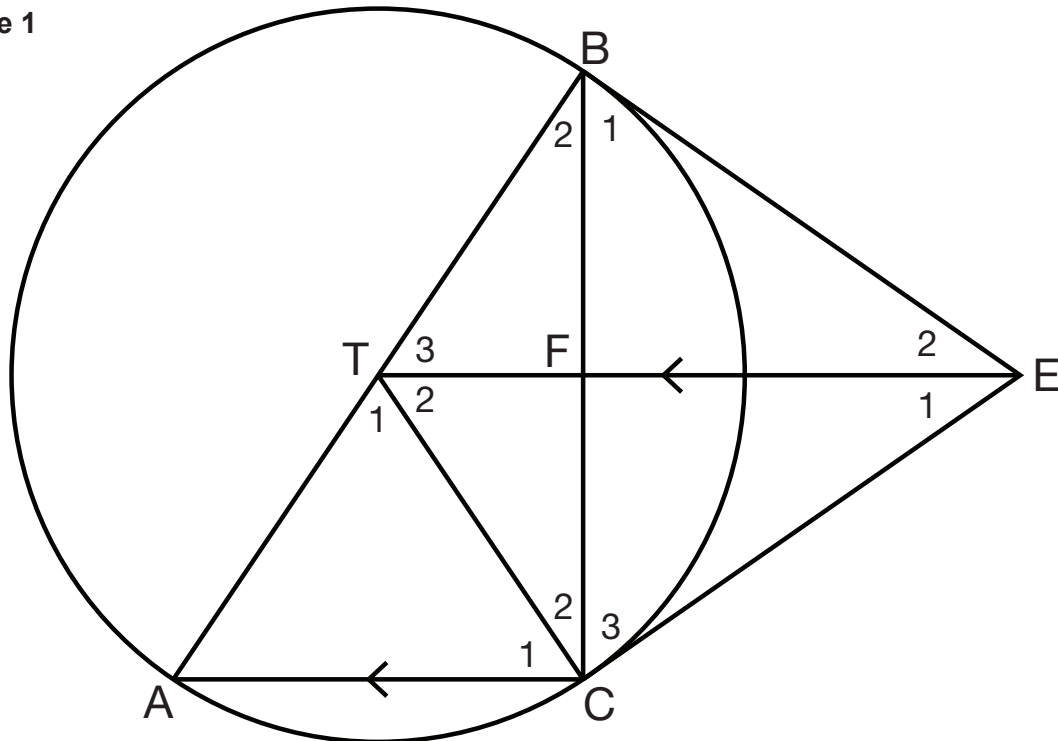

Example 2

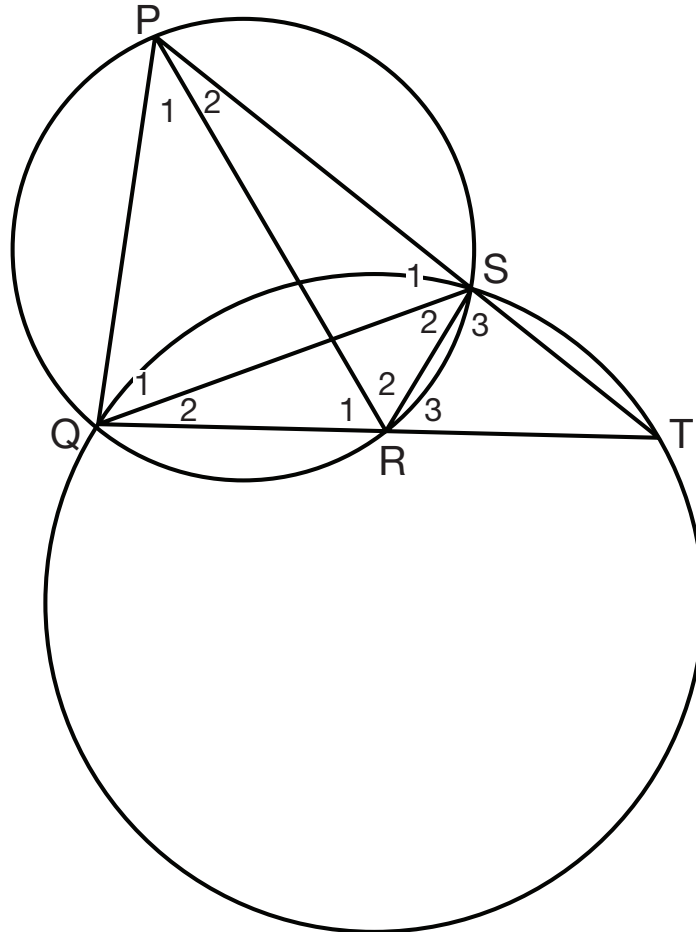

RESOURCE 13

TOPIC 2 LESSON 7

Example 1

a)

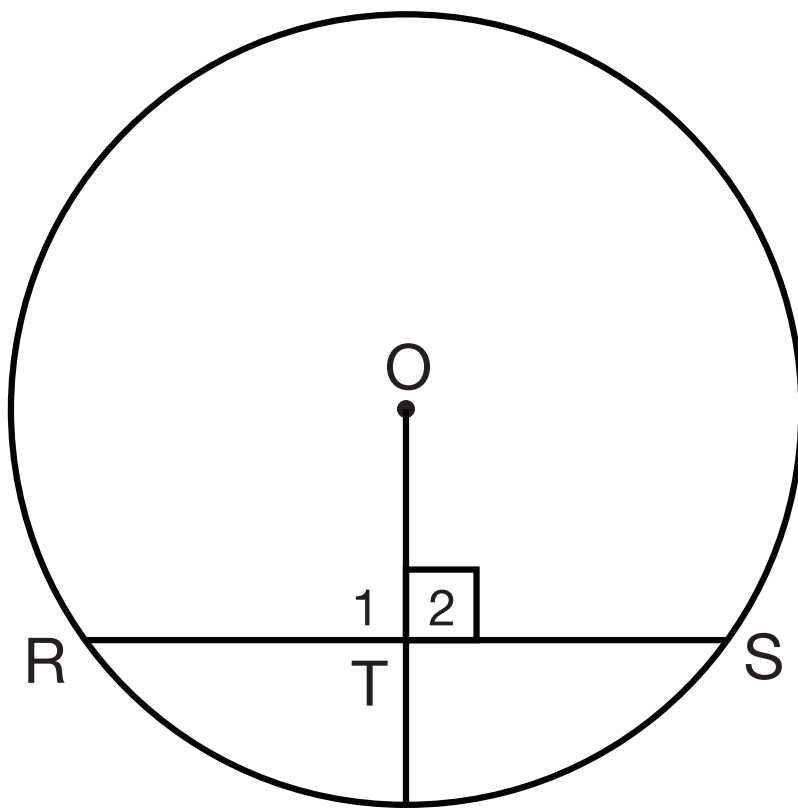

b)

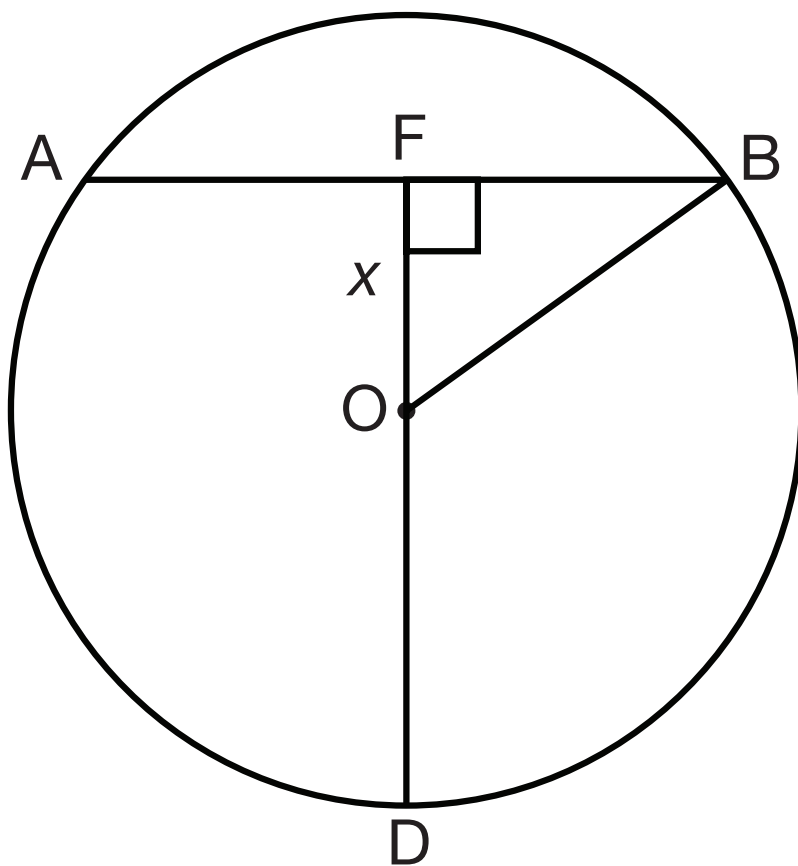

RESOURCE 14

TOPIC 2 LESSON 7

Example 2

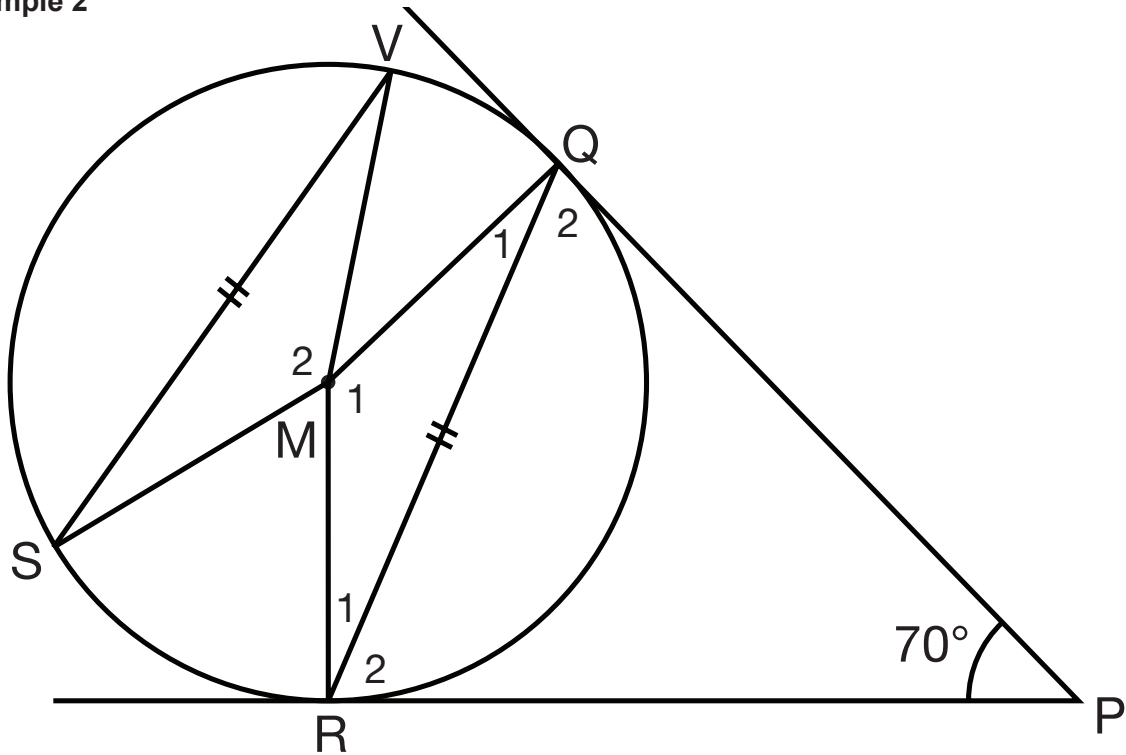

Example 3

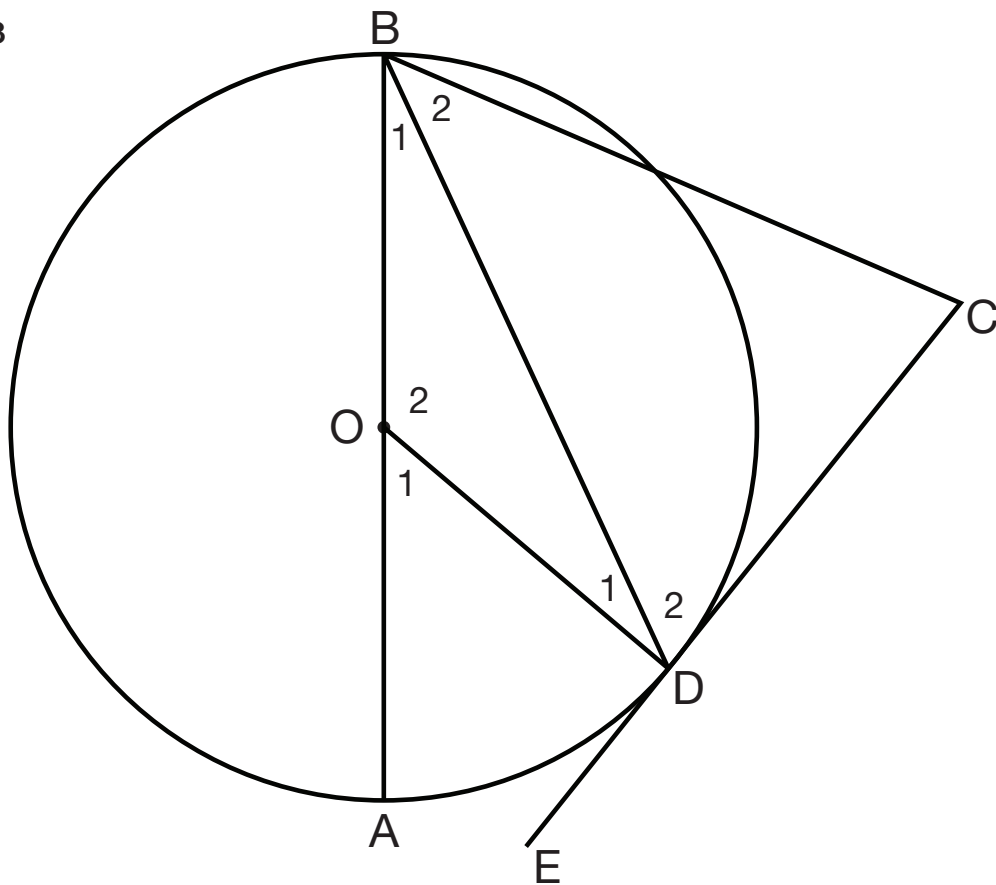

RESOURCE 15

TOPIC 2 LESSON 7

Example 4

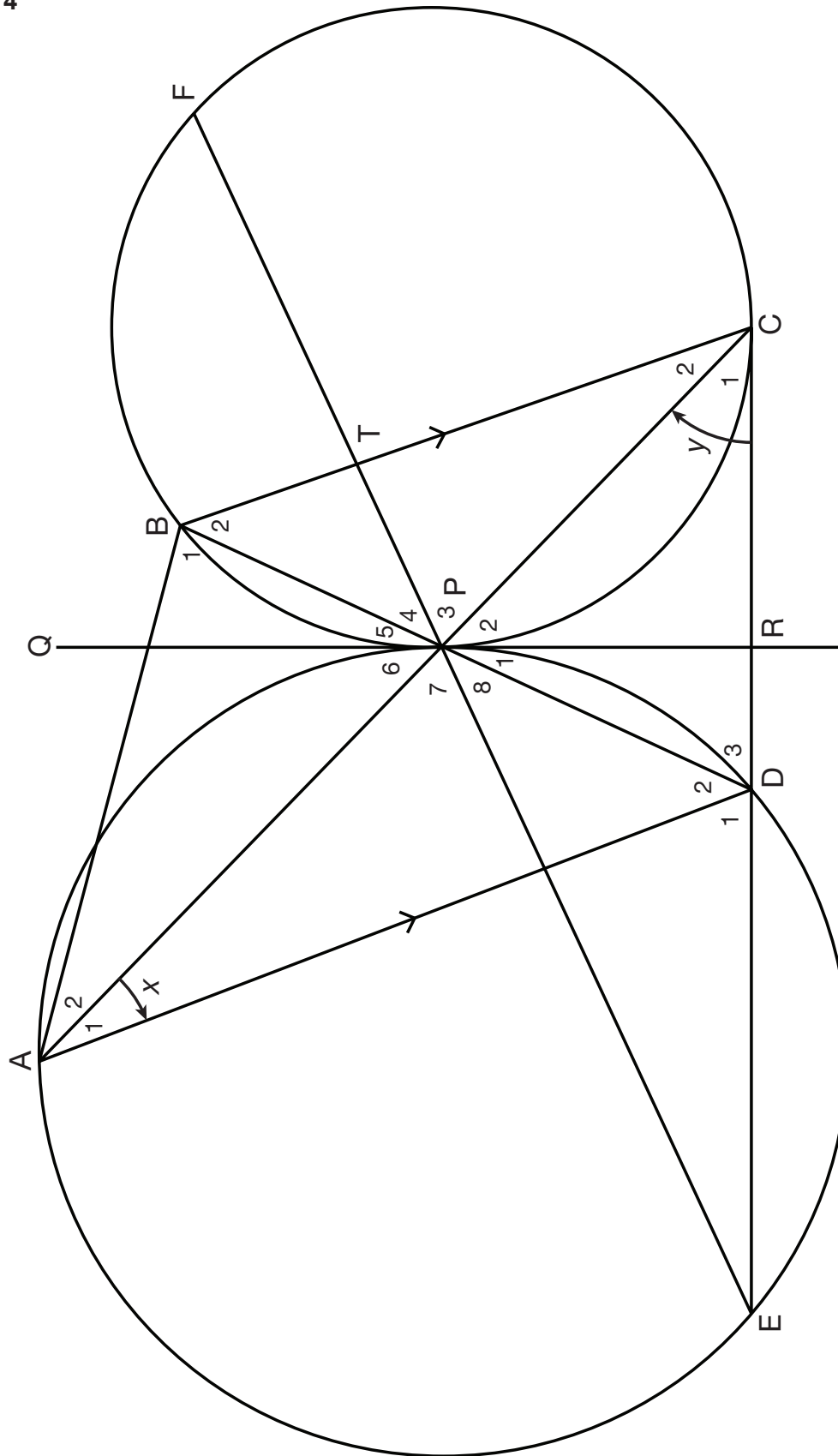

TRIGONOMETRY

RESOURCE 16

TOPIC 3 LESSON 3

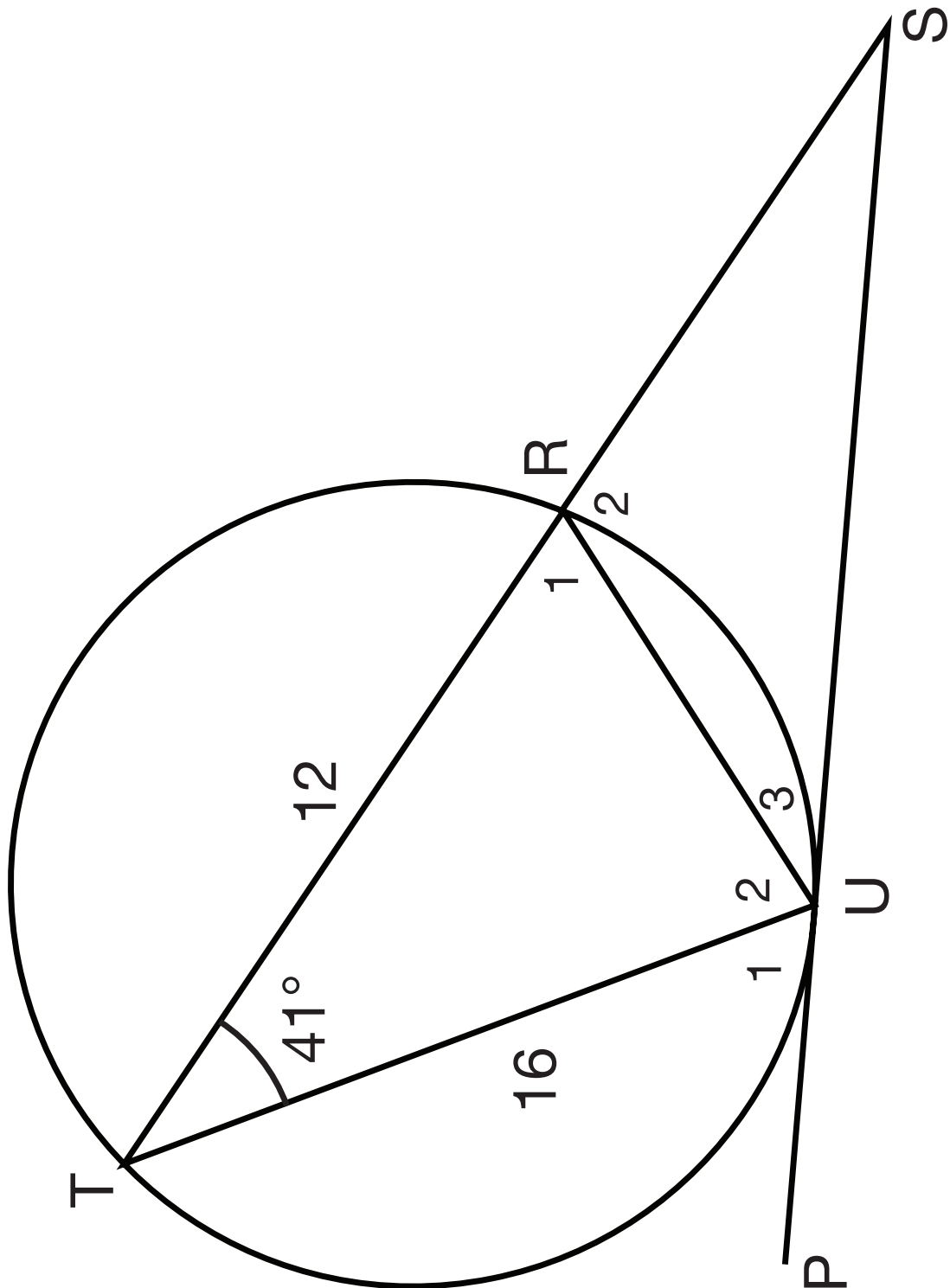

RESOURCE 17

TOPIC 3 LESSON 6

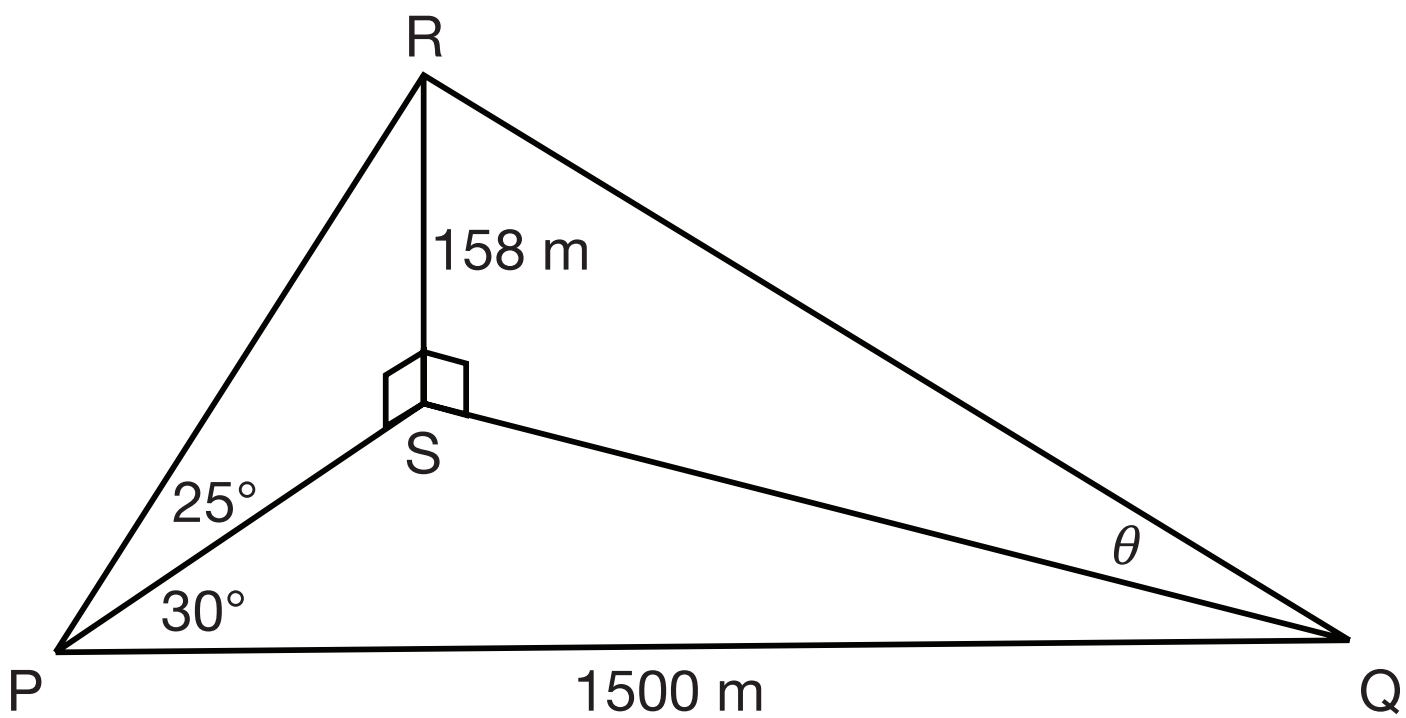
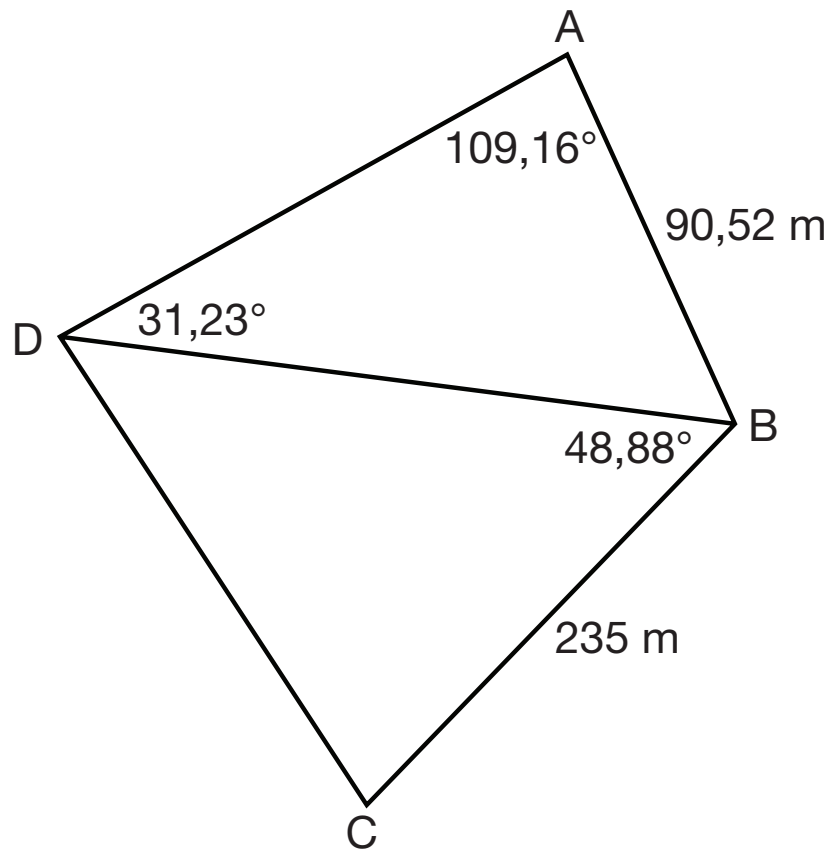

RESOURCE 18

TOPIC 3 LESSON 6

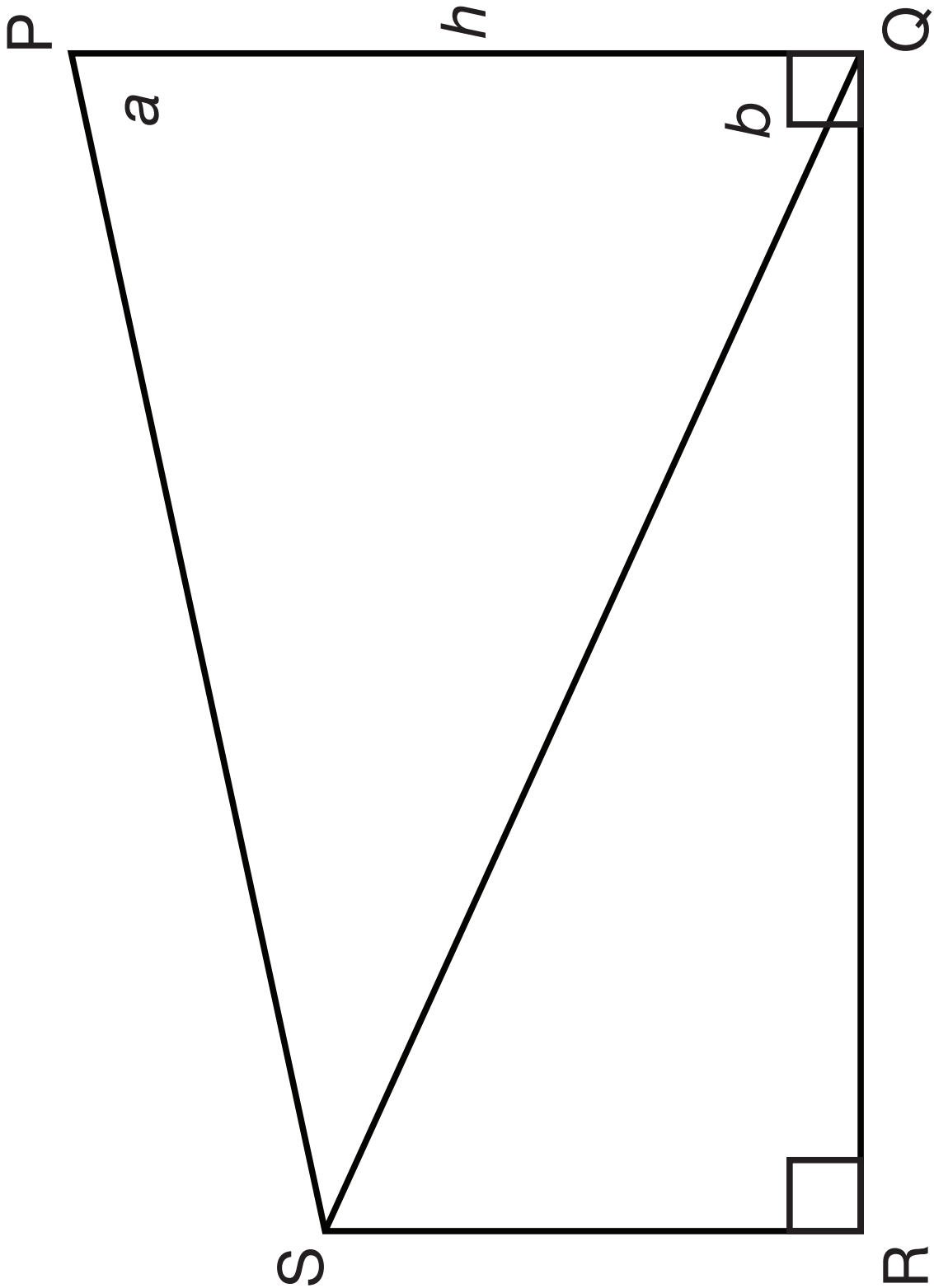

PROBABILITY

RESOURCE 19

TOPIC 5 LESSON 1

Number of passengers, excluding the driver	0	1	2	3	4
Number of cars	7	11	6	5	1

RESOURCE 20

TOPIC 5 LESSON 2

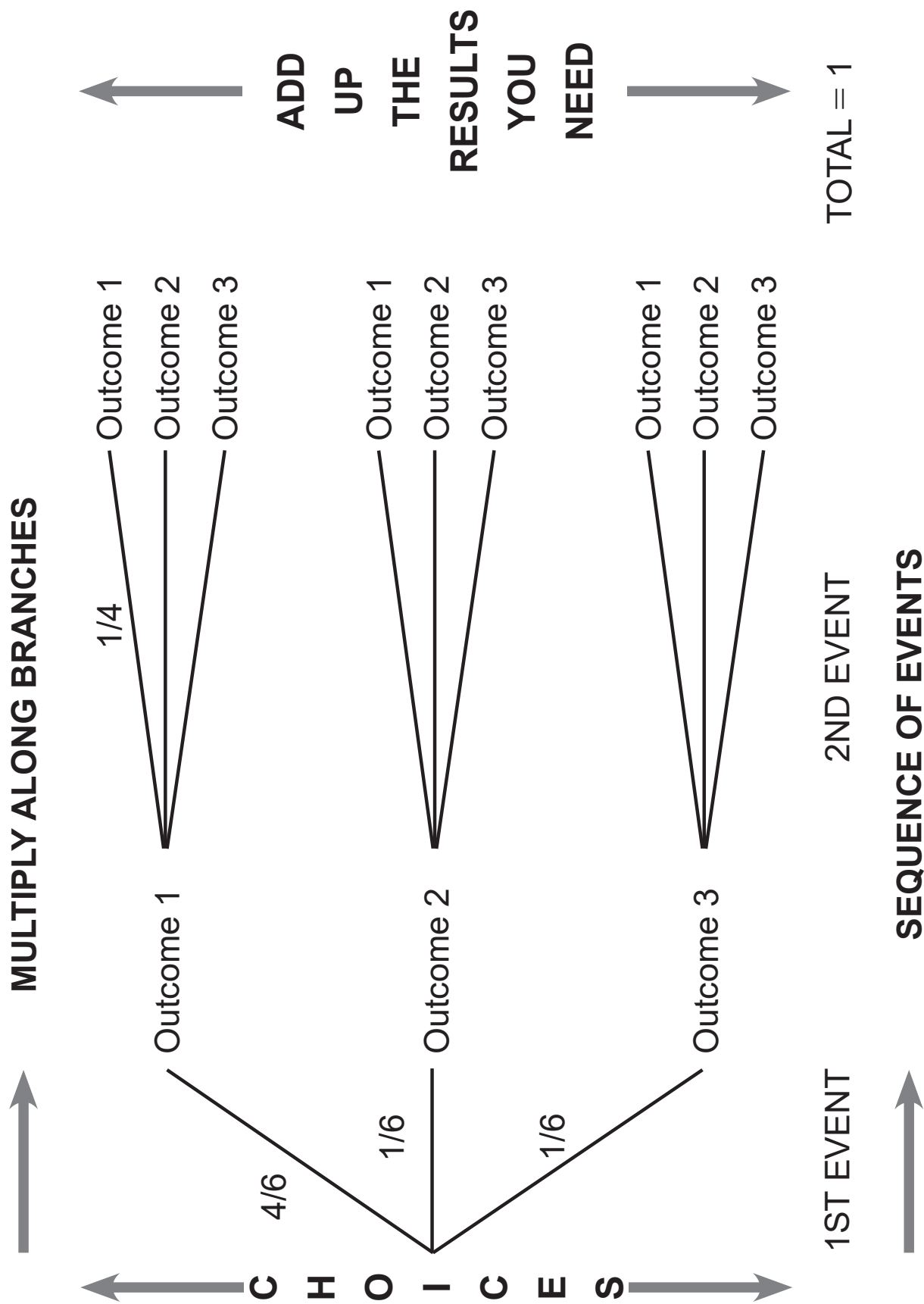

RESOURCE 21**TOPIC 5 LESSON 4**

	Male	Female	Total
Pass	30	47	77
Fail	7	16	23
Total	37	63	100

RESOURCE 22

TOPIC 5 LESSON 5

MONTHLY INCOME (IN RANDS)	AREA 1	AREA 2	TOTAL
$x < 3200$	500	460	960
$3\ 200 \leq x < 25\ 600$	1182	340	1522
$x \geq 25\ 600$	150	14	164
Total	1832	814	2646

RESOURCE 23

TERM 3 TEST 1 AND MEMORANDUM

GR 11 MATHEMATICS TEST 1

QUESTION	DESCRIPTION	MAXIMUM MARK	ACTUAL MARK
1	Euclidean Geometry	29	
2	Trigonometry and Measurement	21	
	TOTAL	50	

INSTRUCTIONS:

1. If necessary, round answers off to two decimal places.
2. Calculators may be used.
3. Formulae:

Volume of a square pyramid = $\frac{1}{3}(\text{area of base})(\perp \text{ height})$

$$\text{In } \triangle ABC: \quad \frac{a}{\sin A} = \frac{b}{\sin B} = \frac{c}{\sin C}$$

$$a^2 = b^2 + c^2 - 2bc \cdot \cos A$$

$$\text{area } \triangle ABC = \frac{1}{2}ab \cdot \sin C$$

QUESTION 1

19 MARKS

1.1 In the diagram, A, B, C and D are points on the circumference of a circle, centre O.

$\widehat{BAD} = 70^\circ$

Find the value of x and y giving reasons. (5)

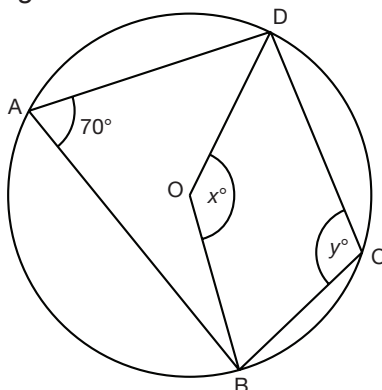

1.2 R and S are two points on a circle, centre O. TS is a tangent to the circle. $\widehat{RST} = x$

Find \widehat{SOR} in terms of x . (7)

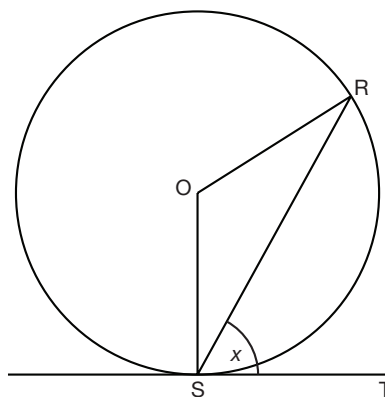

1.3 A, B, C and D are four points on the circumference of a circle. ABE and DCE are straight lines. $\widehat{BAC} = 25^\circ$ and $\widehat{EBC} = 60^\circ$.

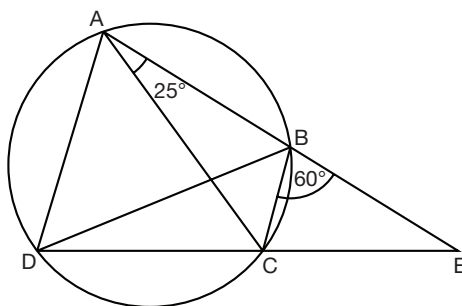

1.3.1 Find \widehat{ADC} . (2)

1.3.2 Find \widehat{ADB} . (3)

1.3.3 $\widehat{CAD} = 65^\circ$. Nozuko says that BD is a diameter of the circle. Is she correct? Justify your answer. (2)

QUESTION 2

10 MARKS

In the diagram, AE is a diameter of the circle with centre O. ABC and EDC are straight lines with $\hat{C} = 50^\circ$. FG is a tangent to the circle at A. AD and BE intersect at H. OB is joined.

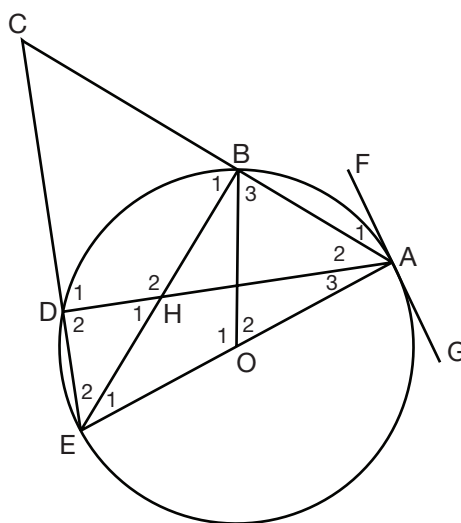

- 2.1 Give a reason why $\hat{ABE} = 90^\circ$ (1)
- 2.2 Hence, prove that BCDH is a cyclic quadrilateral. (4)
- 2.3 Determine the sizes of \hat{H}_1 and \hat{E}_2 with reasons. (2)
- 2.4 If $\hat{A}_1 = x$, determine \hat{E}_1 and \hat{O}_2 in terms of x , giving reasons. (3)

QUESTION 3

6 MARKS

Two small boats are 24m apart. The angle of elevation of the boats to the top of the lighthouse are 20° and 34° respectively.

Calculate the height of the lighthouse. (6)

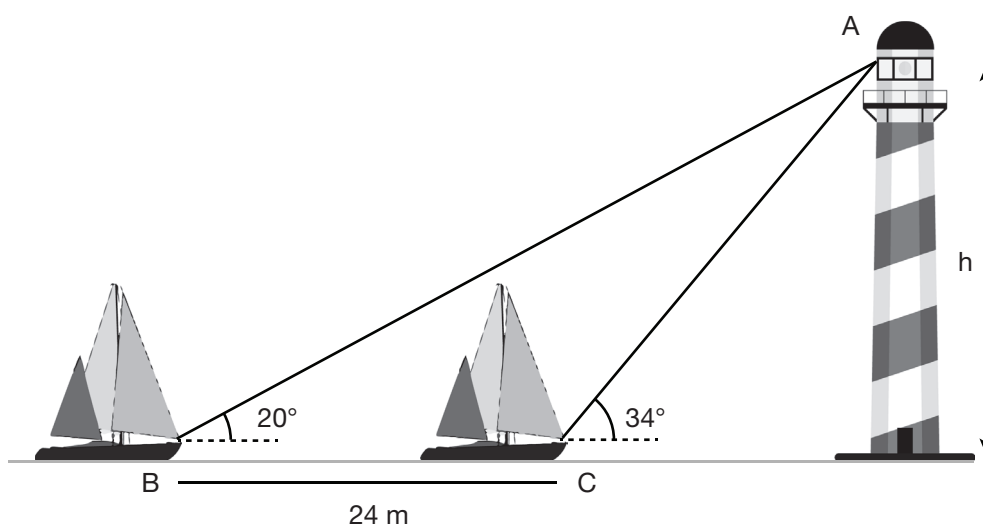

QUESTION 4

15 MARKS

The glass pyramid at the entrance to the Louvre in Paris has a height of 21,95m and a square base that is 34,15m in length.



4.1 Find the volume of the pyramid. (3)

4.2.1 Find the angle of inclination of the side of the pyramid. (3)

4.2.2 If a person 1,75m tall walked from the centre of the pyramid towards the edge, how far away would he be from the edge before he needed to crouch down to reach where the sides meet the base? (3)

4.3 If the triangles on the sides are isosceles, find the size of the angle opposite the base (\hat{A}).
 $AB = AC = 36,25\text{m}$; $BC = 34,15\text{m}$ (4)

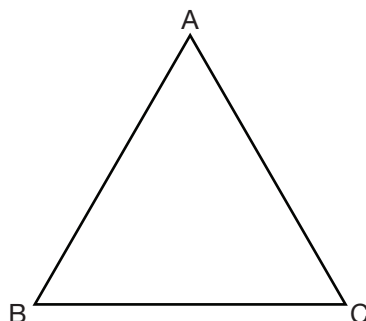

4.4 Hence, find the area of one of the side triangles. (2)

GR 11 MATHEMATICS TEST 1: MEMO

QUESTION	DESCRIPTION	MAXIMUM MARK	ACTUAL MARK
1	Euclidean Geometry	29	
2	Trigonometry and Measurement	21	
	TOTAL	50	

INSTRUCTIONS:

- If necessary, round answers off to two decimal places.
- Calculators may be used.
- Formulae:

Volume of a square pyramid = $\frac{1}{3}(\text{area of base})(\perp \text{height})$

$$\text{In } \triangle ABC: \frac{a}{\sin A} = \frac{b}{\sin B} = \frac{c}{\sin C}$$

$$a^2 = b^2 + c^2 - 2bc \cdot \cos A$$

$$\text{area } \triangle ABC = \frac{1}{2}ab \cdot \sin C$$

QUESTION 1

19 MARKS

1.1 Find the value of x and y giving reasons. (5)

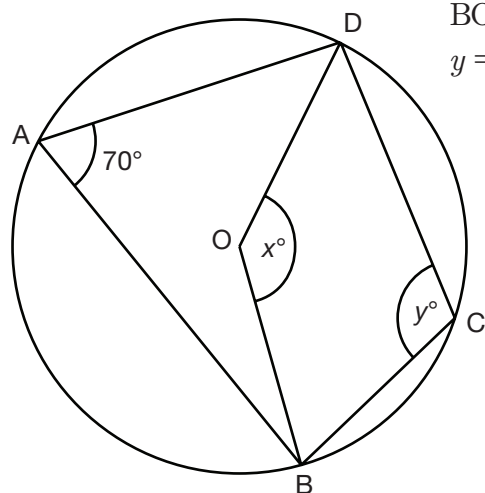

$$x = 140^\circ \checkmark \quad < \text{ at centre} = 2x < \text{ at circumference } \checkmark$$

$$\hat{BOD}_{\text{reflex}} = 220^\circ \checkmark \quad < \text{ 's around pt}$$

$$y = 110^\circ \checkmark \quad < \text{ at centre} = 2x < \text{ at circumference } \checkmark$$

QUESTION 3

6 MARKS

Two small boats are 24m apart. The angle of elevation of the boats to the top of the lighthouse are 20° and 34° respectively.

Calculate the height of the lighthouse.

(6)

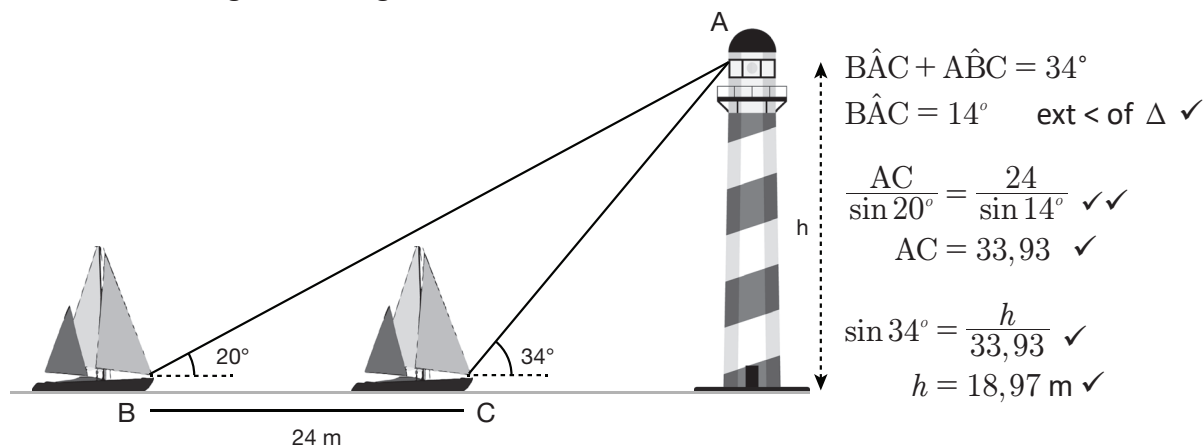

QUESTION 4

15 MARKS

4.1 Volume = $\frac{1}{3}$ base \times height
 $= \frac{1}{3}(34,15)^2(21,95)m^2$
 $= 8532,86m^2$ ✓

4.2.1

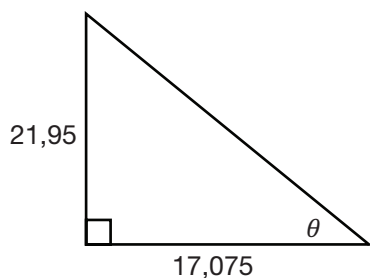

$\tan \theta = \frac{21,95}{17,075}$ ✓✓
 $\therefore \theta = 52,12^\circ$ ✓

4.2.2

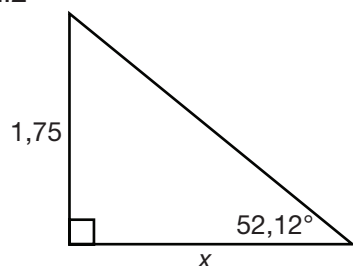

$\tan 52,12^\circ = \frac{1,75}{x}$ ✓
 $x = \frac{1,75}{\tan 52,12^\circ}$ ✓
 $x = 1,36$

4.3 $(34,15)^2 = (36,25)^2 + (36,25)^2 - 2(36,25)^2 \cos A \checkmark\checkmark$
 $1166,2225 = 2628,125 - 2628,125 \cos A$
 $2628,125 \cos A = 1461,9025$
 $\cos A = 0,55625 \dots \checkmark$
 $\hat{A} = 56,2^\circ \checkmark$

4.4 $\text{Area} = \frac{1}{2}bc \sin C$
 $\text{Area} = \frac{1}{2}(36,25)(36,25) \sin 56,2^\circ \checkmark$
 $= 545,98m^2 \checkmark$

QUESTION LEVELS

Question	Knowledge	Routine	Complex	Problem Solve
1.1	5			
1.2			7	
1.3.1	2			
1.3.2		3		
1.3.2		2		
2.1	1			
2.2		4		
2.3		2		
2.4			3	
3				6
4.1	3			
4.2.1			3	
4.2.2			3	
4.3		4		
4.4		2		
Totals	11	17	16	6

50

RESOURCE 24

GR 11 MATHEMATICS TEST 2

QUESTION	DESCRIPTION	MAXIMUM MARK	ACTUAL MARK
1 - 3	Finance	25	
4 - 6	Probability	25	
	TOTAL	50	

INSTRUCTIONS:

- If necessary, round answers off to two decimal places.
- Calculators may be used.
- Formulae:

$$A = P(1 + n.i)$$

$$A = P(1 - n.i)$$

$$A = P(1 + i)^n$$

$$A = P(1 - i)^n$$

$$P(A) = \frac{n(A)}{n(S)}$$

$$P(A \text{ or } B) = P(A) + P(B) - P(A \text{ and } B)$$

QUESTION 1

7 MARKS

Joshua bought a new car for R156 000.

- 1.1 If the expected rate of depreciation is 8,5% p.a. on a reducing balance, calculate the value of the car after 6 years. (3)
- 1.2 Calculate the rate of depreciation if the value of the car falls to R60 000 after 5 years, calculated on the straight-line basis. (4)

QUESTION 2

11 MARKS

John is planning a trip to Europe in 5 years' time. He has seen a holiday advertised for R12 900 for 8 days including accommodation and breakfast.

- 2.1 If the rate of inflation is 6,5% p.a. for the next five years, what will the trip cost by the time John wants to go? (3)

2.2 John intends to pay for the trip by investing R6 000 that he was just paid as a bonus at work. The savings account offers interest of 6% p.a. compounded monthly. 2 years into the investment, the interest changes to 8,5% p.a. compounded quarterly. John gets paid another bonus of R8 500 after 3 years which enables him to make an additional payment.

- 2.2.1 Draw a timeline representing the above information. (2)
- 2.2.2 Find how much John will have saved at the end of the 5 years. (4)
- 2.2.3 If John has an excess of R2 800 and the exchange rate is €1 = R14,82, how many Euros can he buy if the exchange rate is €1 = R14,82? (2)

QUESTION 3

7 MARKS

Mary invests a certain sum of money for 3 years. She receives interest of 9% p.a. compounded monthly for the entire period. The money grows to R8 506,20 by the end of the three years.

- 3.1 Calculate the effective interest rate p.a. for the first year. (4)
- 3.2 Calculate how much money Mary invested initially. (3)

QUESTION 4

7 MARKS

Andile sometimes gets a lift to and from school. When he does not get a lift, he walks. The probability that he gets a lift to school is 0,4. The probability that he walks home from school is 0,7. Getting to school and getting home from school are independent events.

- 4.1 Draw a tree diagram representing the information. Write all the probabilities on the branches. (4)
- 4.2 Calculate the probability that Andile walks at least one way. (3)

QUESTION 5

10 MARKS

5.1 Sketch **2** diagrams like the one below, and shade in the region to represent

- (i) $P(A \text{ or } B)$ (ii) $P(A')$ (2)

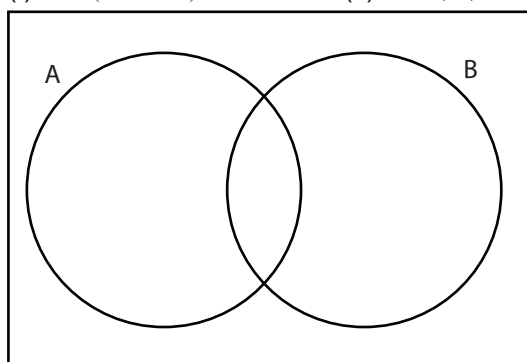

5.2 Q and R are two mutually exclusive events.

(i) Complete: $P(Q \text{ and } R) = \dots$ (1)

(ii) If $P(Q) = 0,32$ and $P(Q \text{ or } R) = 0,51$ find $P(R)$ (3)

5.3 A and B are two events in a sample space.

$$P(A) = 0,38 \quad P(A \text{ or } B) = 0,64 \quad P(B) = t$$

For what value of t , are events A and B independent? (4)

QUESTION 6

8 MARKS

An author makes a visit to a school and meets 100 Grade 11 learners. She asks them whether they have read '*The color purple*' by Alice Walker and '*To kill a mockingbird*' by Harper Lee.

56 indicate that they have read '*The color purple*' and 41 indicate that they have read '*To kill a mockingbird*'. 22 learners had read neither.

6.1 Represent the data in a Venn diagram. (4)

6.2 Determine how many learners had read both books. (2)

6.3 Determine the probability that a learner selected at random had read both books. (2)

GR 11 MATHEMATICS TEST 2: MEMO

QUESTION	DESCRIPTION	MAXIMUM MARK	ACTUAL MARK
1 - 3	Finance	25	
4 - 6	Probability	25	
	TOTAL	50	

INSTRUCTIONS:

- If necessary, round answers off to two decimal places.
- Calculators may be used.
- Formulae:

$$A = P(1 + n.i)$$

$$A = P(1 - n.i)$$

$$A = P(1 + i)^n$$

$$A = P(1 - i)^n$$

$$P(A) = \frac{n(A)}{n(S)}$$

$$P(A \text{ or } B) = P(A) + P(B) - P(A \text{ and } B)$$

QUESTION 1

7 MARKS

1.1 $A = P(1 - i)^n$

$$A = 156\,000(1 - 0,085)^6 \checkmark$$

$$A = R91\,548,49 \checkmark$$

(3R)

1.2 $A = P(1 - i.n)$

$$60\,000 \checkmark = 156\,000(1 - 5i) \checkmark$$

$$\frac{60\,000}{156\,000} = 1 - 5i$$

$$\frac{60\,000}{156\,000} - 1 = -5i \checkmark$$

$$0,123076\dots = i$$

$$\therefore i = 12,31\% \checkmark$$

(4C)

QUESTION 2

11 MARKS

2.1 $A = P(1 + i)^n$

$$A = 12\,900 \checkmark (1 + 0,065)^5 \checkmark$$

$$A = R17\,674,12 \checkmark$$

(3R)

2.2.1

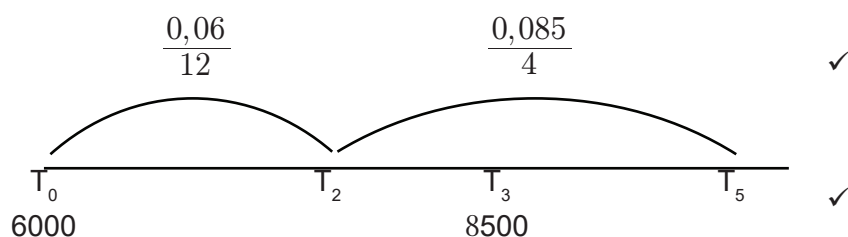

(2R)

$$2.2.2 \quad A = 6000 \left(1 + \frac{0,06}{12}\right)^{24} \left(1 + \frac{0,085}{4}\right)^{12} + 8500 \left(1 + \frac{0,085}{4}\right)^8$$

$$A = R18\,761,22$$

(4P)

$$2.2.3 \quad \frac{2800}{14,82} = 188,933\dots$$

$$\therefore \text{€}188,93$$

(2K)

QUESTION 3

7 MARKS

$$3.1 \quad i_{eff} = \left(1 + \frac{i_{nom}}{n}\right)^n - 1$$

$$i_{eff} = \left(1 + \frac{0,09}{12}\right)^{12} - 1 \quad (/12 \text{ and } ^{12})$$

$$i_{eff} = 0,093806\dots$$

$$i_{eff} = 9,38\%$$

(4C)

$$3.2 \quad P = A(1 + i)^{-n}$$

$$P = 8506,20 \left(1 + \frac{0,09}{12}\right)^{-36}$$

$$P = R6500$$

(3C)

QUESTION 4

7 MARKS

4.1 Tree diagram

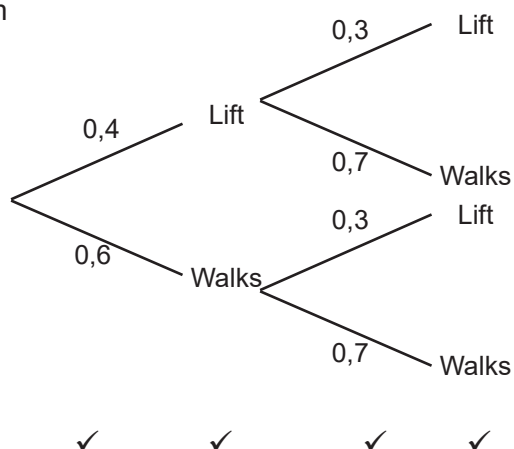

(4C)

$$\begin{aligned}
 4.2 \quad & 1 - (0,4)(0,3) \checkmark\checkmark & \text{OR} & (0,4)(0,7) + (0,6)(0,3) + (0,6)(0,7) \checkmark\checkmark \\
 & = 1 - 0,12 & & = 0,28 + 0,18 + 0,42 \\
 & = 0,88 \checkmark & & = 0,88 \checkmark
 \end{aligned}$$

(3R)

QUESTION 5

10 MARKS

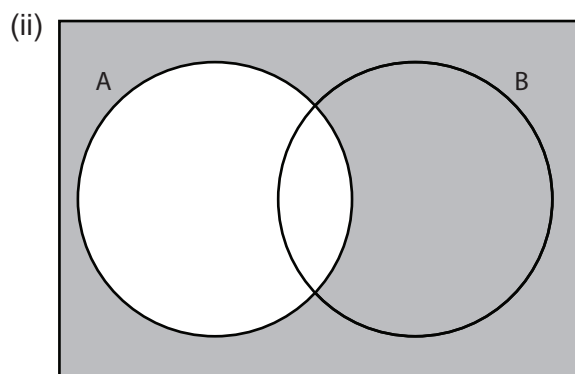
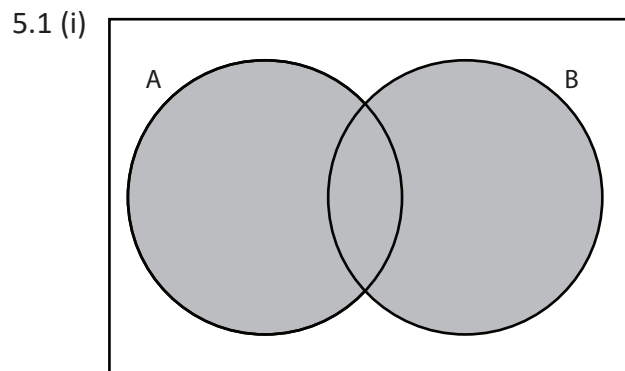

(2K)

5.2 (i) $P(Q \text{ and } R) = 0 \checkmark$

(ii) $P(Q) + P(R) = P(Q \text{ or } R)$

$$0,32 + P(R) = 0,51 \quad \checkmark\checkmark$$

$$P(R) = 0,19 \quad \checkmark$$

(1K)

(3R)

5.3 Independent events: $P(A) \times P(B) = P(A \text{ and } B) \checkmark$

$$\therefore P(A) + P(B) - P(A).P(B) = P(A \text{ or } B)$$

$$0,38 + t - 0,38t = 0,64 \quad \checkmark\checkmark$$

$$0,62t = 0,26$$

$$t = 0,42 \quad \checkmark$$

(4P)

QUESTION 6

8 MARKS

6.1 Venn diagram.

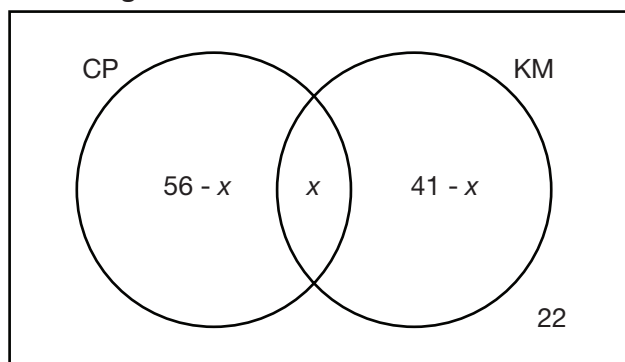

✓ ✓ ✓ ✓

(4R)

6.2 $56 - x + x + 41 - x + 22 = 100$ ✓✓
 $x = 19$

(2K)

6.3 $\frac{78}{100}$ OR 78% ✓✓

(2K)

QUESTION LEVELS

Question	Knowledge	Routine	Complex	Problem Solve
1.1		3		
1.2			4	
2.1		3		
2.2.1		2		
2.2.2				4
2.2.3	2			
3.1			4	
3.2			3	
4.1			4	
4.2		3		
5.1	2			
5.2 (i)	1			
5.2 (ii)		3		
5.3				4
6.1		4		
6.2	2			
6.3	2			
Totals	9	18	15	8

50